



APPLICATION NOTICE

PROPOSED NEW LARGE TRANSMISSION NETWORK ASSET

REDEVELOPMENT OF ORANGE 132/66 kV SUBSTATION

Disclaimer

This document has been prepared and made available solely for information purposes. Nothing in this document can be or should be taken as a recommendation in respect of any possible investment. This document does not purport to contain all of the information that a prospective investor or participant or potential participant in the National Electricity Market, or any other person or interested parties may require. In preparing this document it is not possible nor is it intended for TransGrid or Country Energy to have regard to the investment objectives, financial situation and particular needs of each person who reads or uses this document.

In all cases, anyone proposing to rely on or use the information in this document should independently verify and check the accuracy, completeness, reliability and suitability of that information and the reports and other information relied on by TransGrid and Country Energy in preparing this document, and should obtain independent and specific advice from appropriate experts or other sources.

Accordingly, TransGrid and Country Energy make no representations or warranty as to the accuracy, reliability, completeness or suitability for particular purposes of the information in this document. Persons reading or utilising this document acknowledge that TransGrid, Country Energy and their employees, agents and consultants shall have no liability (including liability to any person by reason of negligence or negligent misstatement) for any statements, opinions, information or matter (expressed or implied) arising out of, contained in or derived from, or for any omissions from, the information in this document, except insofar as liability under any New South Wales and Commonwealth statute cannot be excluded.

Table of Contents

Executive Summary	3
1. Introduction	4
1.1. Purpose and Scope	4
1.2. Outline of Consultation Process	4
2. Identification of a Necessity for Augmentation.....	5
2.1. Regulatory Requirements	5
2.1.1. Requirements of the National Electricity Rules.....	5
2.1.2. Requirements of the Regulatory Test.....	5
2.2. Regulatory Requirements	5
2.2.1. Requirements of the Energy Services Corporations Act	5
2.2.2. Reliability Criterion	6
2.3. Local Supply Arrangements.....	7
2.4. Local Load Forecast	9
2.5. Description of Network Limitations	11
2.5.1. 132 kV Bus Section Circuit Breaker.....	11
2.5.2. Refurbishment Orange 132/66 kV Substation	11
2.5.3. Refurbishment of the Orange – Wallerawang 132 kV Line No 944.....	11
2.5.4. Outage of the 94X Wallerawang – Panorama 132 kV Line	11
2.6. Joint Planning	12
2.7. Reliability Augmentation	12
2.8. Material Internetwork Impact.....	12
2.9. Consideration of DSM and Local Generation	12
3. Options.....	13
3.1. Option 1: Orange 132 kV Switching Station	14
3.2. Option 2: New Orange 132/66 kV Substation.....	16
3.3. Notes on Options 1 and 2	17
3.4. Consideration of Other Network Developments	17
3.4.1. Other Sites in the Orange Area	17
3.4.2. Expansion and Refurbishment of Orange 132/66 kV Substation	17
4. Preliminary Application of the Regulatory Test.....	18
4.1. Form of the Regulatory Test	18
4.2. Preliminary Regulatory Test Application – Summary	18
4.2.1. Costs	18
4.2.2. Scenarios	18
4.2.3. Results	19
5. Preliminary Conclusions and Preferred Actions	20
6. Contact Details for Submissions and Enquiries.....	20
Appendix A - Present Value Cost Analysis of Base Case	21

Executive Summary

This application notice has been prepared to provide a basis for TransGrid and Country Energy to consult with registered participants and interested parties to identify options for the redevelopment of Orange 132/66 kV substation that will be included in an application of the Australian Energy Regulator's regulatory test.

Section 1 provides the context of this application notice within the regulatory process. It is proposed to allow interested parties to make submissions and provide other feedback in the period to 21/04/2009. A final report that will include a decision on the proposed actions is envisaged to be published in the period to July 2009.

Section 2 describes in detail the regulatory requirements relating to proposals for new large transmission network assets, the existing 132 kV supply arrangements at Orange and the network limitations that give rise to a need to refurbish and augment Orange 132 kV substation. The agreed network performance requirements (planning criterion) against which the need and effectiveness of augmentation options are assessed are also described.

In Section 3 two feasible network augmentation options are described. Option 1 involves the construction of a new 132 kV switching station and 132 kV line rearrangements near Orange. Option 2 involves the construction of a new 132/66 kV substation and 132 kV line rearrangements near Orange. Each option is combined with works to refurbish the 66 kV busbar and other 66 kV equipment at Orange 132/66 kV substation, this work being required for asset condition reasons. A number of other network developments that were considered but not put forward as reasonable options are also described. The capital costs of the options are around \$46 million for Option 1 plus \$10 Million for the 66 kV refurbishment works, and \$58 million for Option 2 plus \$3 Million for the 66 kV refurbishment works. Each Option could be completed by late 2011 and the 66 kV refurbishment works by mid 2013.

In Section 4 the results of a preliminary application of the regulatory test considering Options 1 and 2 are presented.

In Section 5 it is concluded that Option 1 is the lowest cost option in all cases and would satisfy the regulatory test. On this basis, subject to completion of the consultation process, the preferred actions are for TransGrid to proceed with construction of Option 1 and the associated 66 kV refurbishment works.

Section 6 provides contact details for provision of written submissions on this application notice.

1. Introduction

1.1. Purpose and Scope

TransGrid owns the majority of the transmission network within NSW and is responsible inter alia for planning and developing its network to meet the requirements of customers within the state and to facilitate operation of the National Electricity Market (NEM). As part of its planning responsibilities and the requirements of the National Electricity Rules (the Rules) TransGrid consults with NEM registered participants, NEMMCO and interested parties on emerging limitations within its transmission network and options being considered to relieve them.

Country Energy owns the subtransmission and distribution networks in the Orange area and is responsible for planning and developing those networks.

TransGrid and Country Energy have responsibilities under the Rules to carry out joint planning to facilitate the optimal development of connections between the transmission and distribution networks within Country Energy's network area.

This application notice has been prepared in accordance with Clause 5.6.6 (c) of the Rules. It relates to a proposal for a new large transmission network asset that will address network limitations in the Orange area that will necessitate redevelopment of Orange 132/66 kV substation.

It includes:

- A summary of the load forecast for the area;
- A description of the network reliability criterion that has been adopted for planning purposes;
- A description of transmission network limitations identified by TransGrid and Country Energy that have led to the necessity for redevelopment of Orange 132/66 kV substation;
- A description of all reasonable network and non-network options that have been identified to meet these limitations;
- An analysis of the ranking of these options in accordance with the Australian Energy Regulator's (AER's) regulatory test;
- A preliminary assessment of the outcome of the regulatory test and proposed actions; and
- An invitation to NEM registered participants and interested parties to make submissions on this application notice.

1.2. Outline of Consultation Process

TransGrid has published a description of limitations affecting Orange 132/66 kV substation in its Annual Planning Report (APR) for 2008.

This application notice covers consultation and application of the regulatory test to reasonable network and non-network options to meet these limitations and is the first step in the formal consultation process that is required by the Rules.

A summary of this application notice has been published on NEMMCO's website. In accordance with Clause 5.6.6 of the Rules it is intended to proceed with further consultation on this new large transmission network asset proposal as follows:

Interested parties have until 21/04/2009 to provide written submissions in respect of this proposal - refer to Section 6 for contact details.

The Rules provide for further periods of 30 business days for the consideration of submissions and 21 business days for holding meetings with interested parties (if required) prior to the publication of a final report on the proposal that will include a decision on the proposed actions.

The final report for this proposal is envisaged to be published in the period to July 2009.

2. Identification of a Necessity for Augmentation

2.1. Regulatory Requirements

2.1.1. Requirements of the National Electricity Rules

This application notice covers a proposal for a new large transmission network asset.

The requirements of the Rules for new large transmission network asset proposals are set out in Clause 5.6.6. This requires applicants (in this case TransGrid) inter-alia to:

- Set out the reasons for proposing the new large transmission network asset including the actual or potential constraint or inability to meet network performance requirements;
- Describe all reasonable network and non-network options to address the constraint;
- Rank the options in accordance with the principles of the AER's regulatory test including detailed analysis of why the applicant considers the new large transmission network asset satisfies the regulatory test;
- Where relevant provide analysis of why the applicant considers the new large transmission network asset is a reliability augmentation; and
- Provide an augmentation technical report or consents to proceed from affected Transmission Network Service Providers if the new large transmission network asset is likely to have a material internetwork impact.

These requirements are underpinned by Clause 5.6.2 (c) of the Rules which requires that a necessity for an *augmentation* or *extension* to the transmission system should be identified by network service providers.

2.1.2. Requirements of the Regulatory Test

The regulatory test may be applied in either one of two ways. The regulatory test states that an option satisfies the test if:

- (a) in the event the option is necessitated principally by inability to meet the service standards linked to the technical requirements of schedule 5.1 of the Rules or in applicable regulatory instruments - the option minimises the costs of meeting those requirements, compared with alternative option/s in a majority of reasonable scenarios;
- (b) in all other cases - the option maximises the expected net economic benefit to all those who produce, consume and transport electricity in the national electricity market compared to the likely alternative option/s in a majority of reasonable scenarios. Net economic benefit equals the market benefit less costs.

The Rules define a reliability augmentation as:

A transmission network augmentation that is necessitated principally by inability to meet the minimum network performance requirements set out in schedule 5.1 or in relevant legislation, regulations or any statutory instrument of a participating jurisdiction.

Thus for reliability augmentations clause (a) of the test should be used. That is for reliability augmentations the option that satisfies the regulatory test is the one that minimises the cost of meeting the minimum network performance requirements set out in schedule 5.1 of the Rules or via a jurisdictional or customer requirement.

2.2. Regulatory Requirements

2.2.1. Requirements of the Energy Services Corporations Act

TransGrid's enabling legislation is the Energy Services Corporation Act 1995. Section 6B of the Act sets out the five principal objectives which in summary are:

1. To be a successful business. This includes:
 - a. To operate at least as efficiently as any comparable business;
 - b. To maximise the net worth of the State's investment in it;

Application Notice - Redevelopment of Orange 132/66 kV Substation

- c. To exhibit a sense of social responsibility by having regard to the interest of the community in which it operates;
2. To protect the environment by conducting its operations in compliance with the principles of ecologically sustainable development;
3. To exhibit a sense of responsibility to regional development;
4. To operate efficient, safe and reliable facilities; and
5. To promote effective access.

It is important to note that the Act explicitly identifies that each of these objectives is of equal value, and thus a balanced approach must be taken in decision making to reflect this obligation. In particular it is worth noting that efficiency is not superior to the environment or the community.

When developing options to overcome actual or potential network constraints, TransGrid initially assesses possible options against the above requirements and then applies the regulatory test to those which satisfy them.

Possible options which were considered but not pursued are described in Section 3.4.

2.2.2. Reliability Criterion

As stated in its Annual Planning Report TransGrid is expected by the NSW jurisdiction to plan and develop its transmission network on an "N-1" basis. That is, unless specifically agreed otherwise by TransGrid and the affected distribution network owner or major directly connected end-use customer, there will be no inadvertent loss of load (other than load which is interruptible or dispatchable) following an outage of a single element (a line or a cable) or transformer, during periods of forecast high load. Consideration is also given to the need to cater for busbar section outages. Accordingly a 132 kV bus section circuit breaker is generally considered necessary when the peak load supplied by that busbar exceeds 120 MW.

These requirements are underpinned by mandatory licence conditions for New South Wales Distribution Network Service Providers. The licence conditions for Country Energy specify N-1, one minute reliability levels for subtransmission lines and zone substations supplying loads greater than or equal to 15 MVA in urban and non-urban areas. Consequently Country Energy has requested TransGrid to incorporate N-1 reliability levels into its planning standards and processes.

In accordance with these principles TransGrid and Country Energy have jointly agreed that the network performance requirements for reliability to be applied in this case are as follows:

1. With all network elements in service the loading on each element is not to exceed the continuous rating of that element and the voltage levels at end-user premises are to be within acceptable levels.
2. Following outage of one network element the loading on each remaining element is not to exceed the short time emergency rating of that element whilst operator actions, such as opening of other network elements and transferring of loads via lower voltage networks, are taking place.
3. With one network element out of service and following operator actions:
 - The loading on each remaining element is not to exceed the sustained emergency rating of that element;
 - The voltage levels at end-user premises are to be within acceptable levels following switching of reactive plant and operation of transformer tap-changers. This requires that voltages at the low voltage busbars of TransGrid substations do not fall below 1.05 per unit.
4. As the load supplied from Orange 132 kV substation is in excess of 120 MW the installation of a 132 kV bus section circuit breaker or equivalent development is required.

In terms of network reliability standards as described in the Rules this constitutes a nominal "N-1" reliability criterion (as described in S5.1.2.2 (b) (4)).

2.3. Local Supply Arrangements

Orange 132/66 kV substation supplies load in Orange township and parts of the Cabonne and Blayney local government areas. These areas have a population of around 40,000. The electrical load consists of a major mine, urban residential loads and commercial/light industrial loads in Orange and rural loads in surrounding areas.

The area of interest is indicated by the dashed circle in Figure 1. TransGrid's 132 kV network supplying this area is shown in schematic form in Figure 2.

Figure 1 – Orange Area of New South Wales

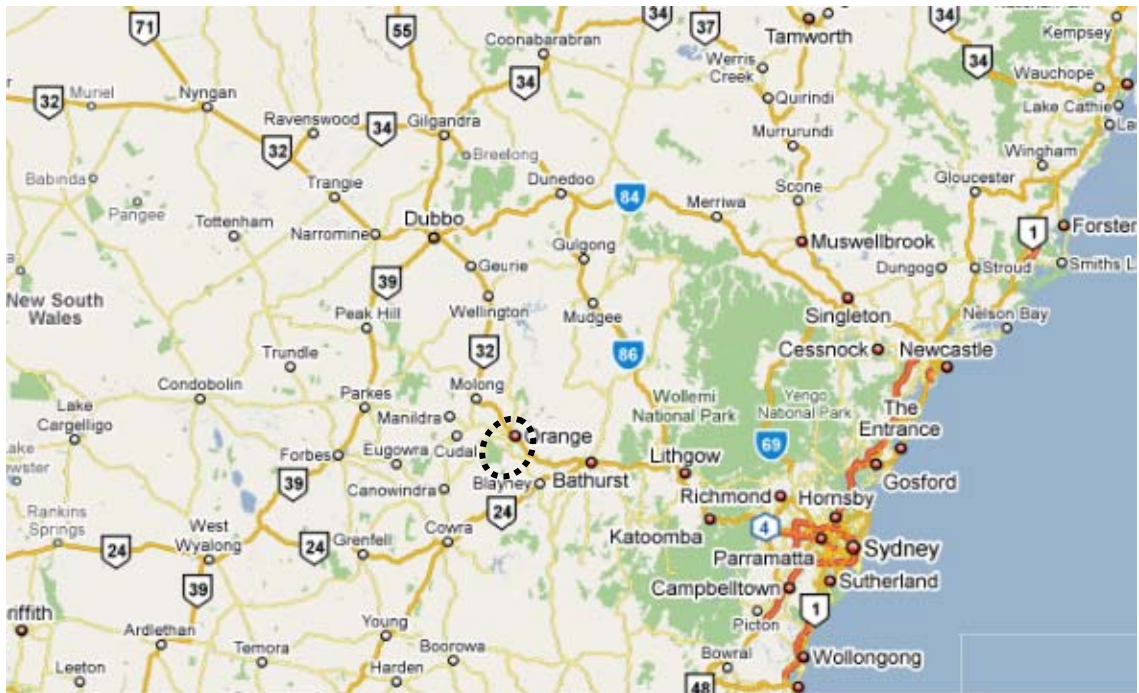

Application Notice - Redevelopment of Orange 132/66 kV Substation

Figure 2 - 132 kV Transmission Network Supplying the Orange Area

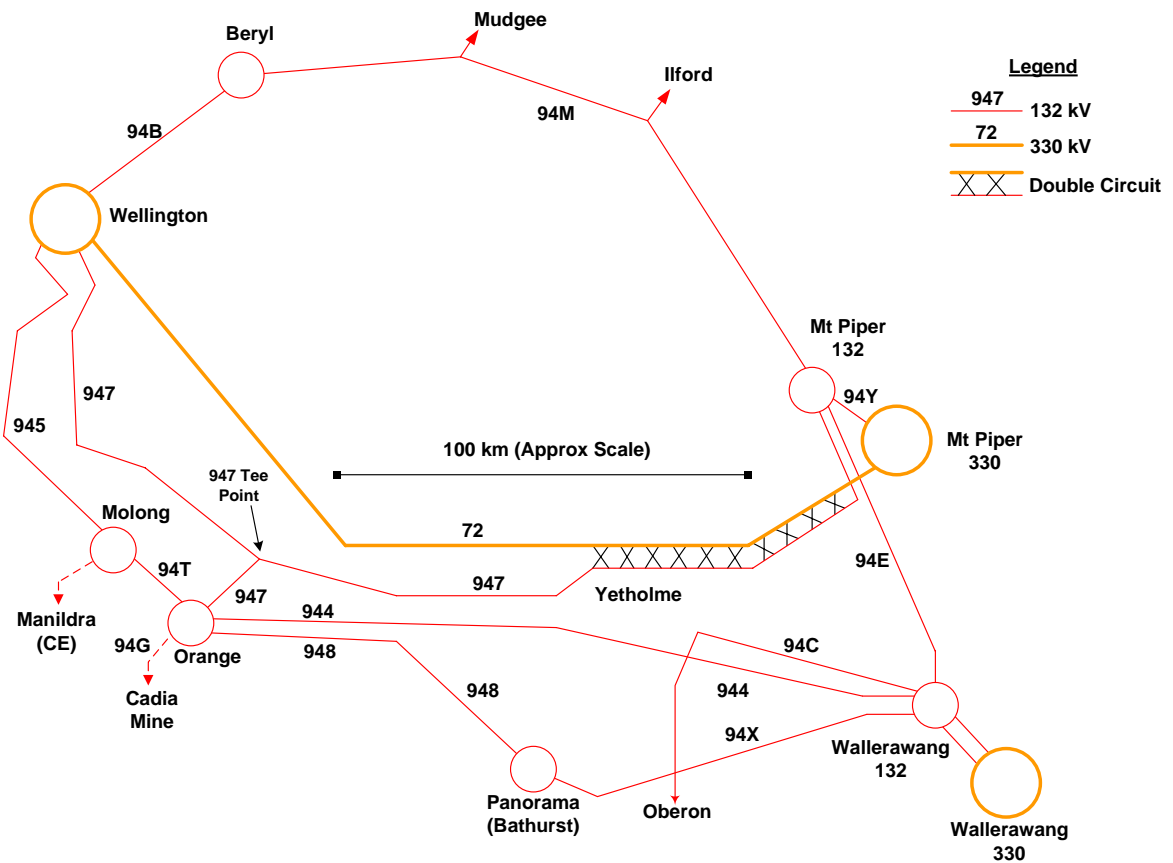

Of particular note are the 132 kV lines connecting to Orange 132/66 kV substation: 944 to Wallerawang, 947 to Mt Piper and Wellington, 948 to Panorama, 94G to the Cadia mine and 94T to Molong.

Figure 3 details 132 kV and 66 kV connections at the substation. The 132/66 kV transformers shown are new units that will replace the three existing 30 MVA 132/66 kV transformers by mid 2009.

Application Notice - Redevelopment of Orange 132/66 kV Substation

Figure 3 Connections at Orange 132/66 kV Substation once the Existing Transformers have been Replaced

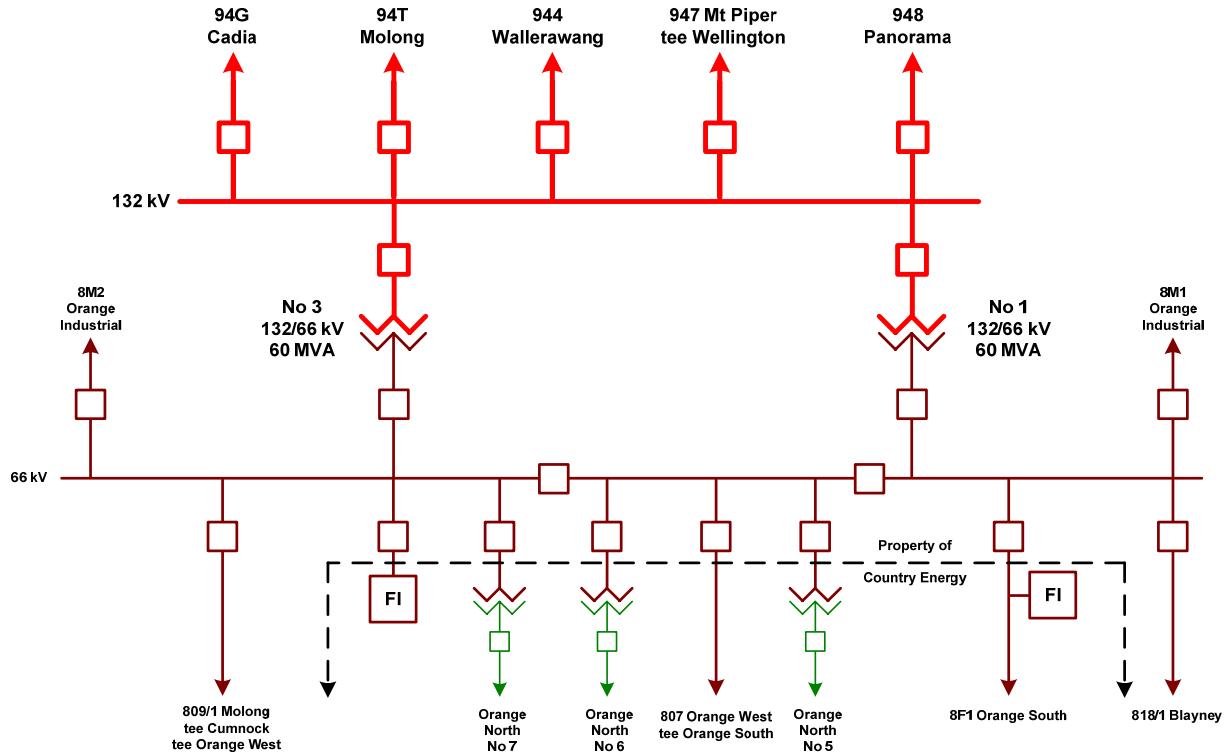

2.4. Local Load Forecast

Country Energy takes supply at 66 kV and 132 kV from Orange 132/66 kV substation. The most recent forecast winter and summer maximum demands for these supply points are shown in Table 1 and Table 2 below.

Table 1 Orange 132/66 kV Substation - Winter Peak Demand Forecasts (MW)

Supply Point	2008	2009	2010	2011	2012	2013	2014	2015	2016	2017
Orange 66 kV	67	68	69	70	71	72	72	73	74	75
Orange 132 kV	83	84	91	92	93	94	95	97	98	99
Total	151	153	160	162	164	166	168	170	172	174
Diversified Total	146	148	155	157	159	161	163	165	167	169

Table 2 Orange 132/66 kV Substation - Summer Peak Demand Forecasts (MW)

Supply Point	2008/ 09	2009/ 10	2010/ 11	2011/ 12	2012/ 13	2013/ 14	2014/ 15	2015/ 16	2016/ 17	2017/ 18
Orange 66 kV	50	51	52	52	53	54	54	55	56	56
Orange 132 kV	83	84	90	91	92	93	95	96	97	98
Total	133	135	141	143	145	147	149	151	153	155
Diversified Total	129	131	137	139	141	143	144	146	148	150

Figure 4 shows actual and forecast winter maximum demands (in MW) for Orange 132/66 kV substation.

Application Notice - Redevelopment of Orange 132/66 kV Substation

Figure 4 Actual and Forecast Winter Max Demands

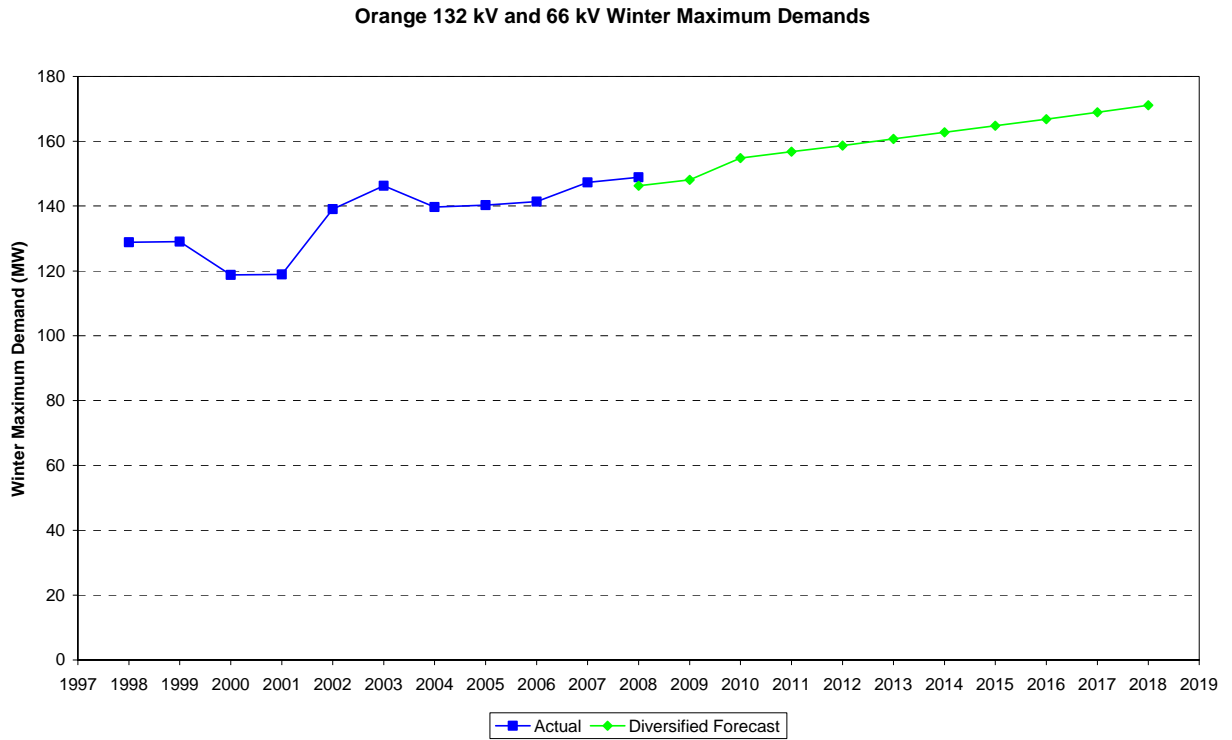
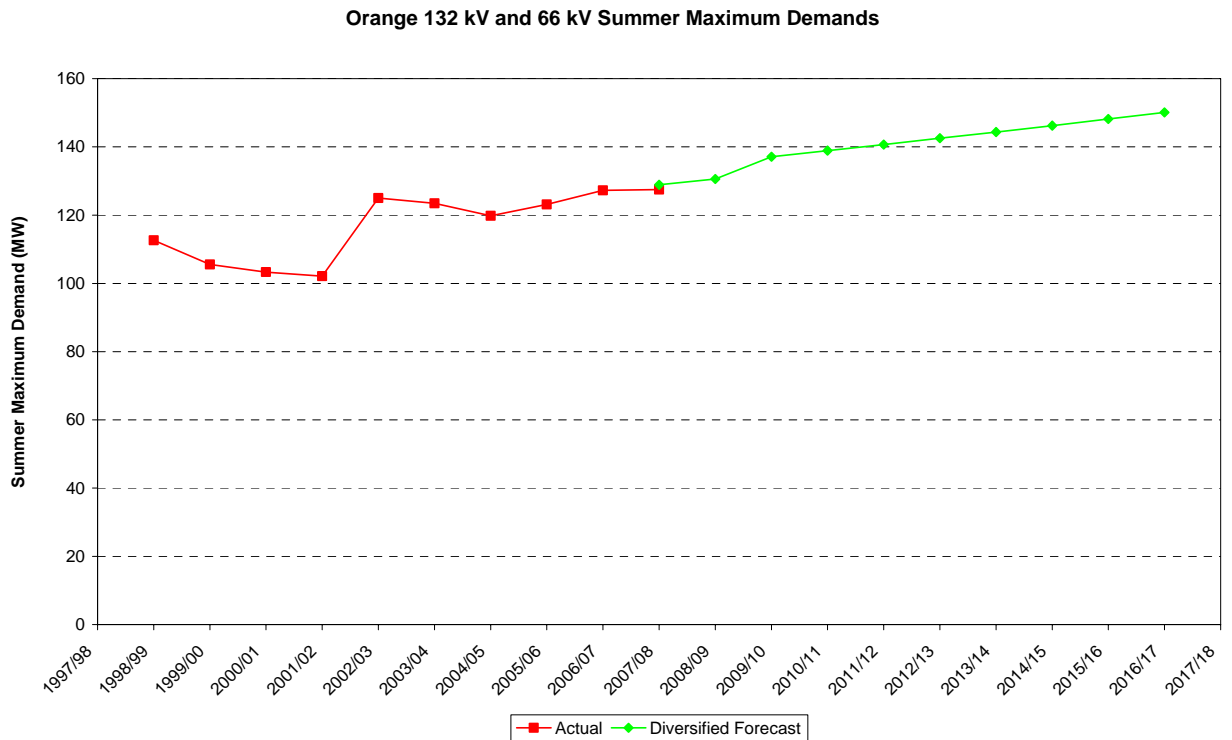

Figure 5 below shows historical and forecast summer maximum demands (in MW) for Orange 132/66 kV substation.

Figure 5 Actual and Forecast Summer Maximum Demands



2.5. Description of Network Limitations

If all elements of the 132 kV network are in service Orange 132/66 kV substation is presently capable of adequately supplying its 132 kV and 66 kV loads at all times within a ten year planning horizon. However limitations presently exist or are expected to emerge as described in the following sections.

2.5.1. 132 kV Bus Section Circuit Breaker

The peak combined 132kV and 66 kV load supplied from Orange 132/66 kV substation presently exceeds 120 MW in both summer and winter. In accordance with the agreed reliability criterion (refer to Section 2.2.2) a 132 kV bus section circuit breaker is required to be provided at Orange 132/66 kV substation or an equivalent development is required in the Orange area.

Orange 132/66 kV substation is in the central part of Orange and is bounded on all sides by various urban developments. There is no free space at the site to accommodate the new 132 kV bus section circuit breaker or the 132 kV line switchbay described in Section 2.5.3. Expansion of the substation on adjacent land is not feasible.

2.5.2. Refurbishment Orange 132/66 kV Substation

Orange 132/66 kV substation is one of TransGrid's oldest substations. Some 132 kV equipment at the site dates from 1955 and most of the 66 kV equipment from 1969. The majority of the equipment and its associated control and protection systems is either due for replacement or approaching that point.

The 66 kV busbar and connections will need to be replaced together with control and protection systems. Much of the original 132 kV main equipment has been replaced in recent years and is in adequate condition. However some older 132 kV main equipment remains and will need to be replaced. Also certain remedial civil works need to be carried out on the site.

The three existing 30 MVA 132/66 kV transformers at the site are being replaced by two new 60 MVA units with this work planned for completion by mid 2009. These new units would be retained following any redevelopment of Orange 132/66 kV substation.

For similar reasons to those described in Section 2.5.1 there is insufficient space to allow the substation to be redeveloped on the existing site.

2.5.3. Refurbishment of the Orange – Wallerawang 132 kV Line No 944

The Orange – Wallerawang 132 kV Line No 944 was built in 1949. It is at the end of its serviceable life and is planned to be replaced by a new 132 kV line on the route of the existing line. Consequently 944 line will be out of service during the rebuild period which will be of about one year duration commencing around 2012.

During this rebuild period the 132 kV network in the Orange area may be limited by a number of single contingencies including outages of the Orange – Mt Piper – Wellington 132 kV line 947. In order to mitigate the affects of these outages without constructing significant lengths of new 132 kV line in the area it will be necessary to loop the Orange – Mt Piper – Wellington 132 kV line 947 into Orange 132/66 kV substation to form separate Mt Piper – Orange and Orange – Wellington 132 kV circuits. Much of the section of 947 line between the tee point and Orange 132/66 kV substation is of double circuit construction so that only short lengths of 132 kV line will need to be constructed.

A new 132 kV line switchbay will be required at Orange to connect the additional 132 kV circuit. As indicated in Section 2.5.1 there is no free space at the site to accommodate this switchbay.

2.5.4. Outage of the 94X Wallerawang – Panorama 132 kV Line

If the 94X Wallerawang – Panorama 132 kV line is out of service at times of high demand the Orange – Mt Piper – Wellington 132 kV line 947 may be overloaded in the section between the tee point and Orange 132/66 kV substation. This limitation is expected to arise from Summer 2010/11.

2.6. Joint Planning

Country Energy and TransGrid have jointly planned the 330 kV and 132 kV network supplying the Orange area for many years.

TransGrid and Country Energy have carried out joint annual planning reviews as required by Clause 5.6.2 (b) of the Rules. As required by Clause 5.6.2(c) they have identified that the limitations described in Section 2.5 give rise to a need for network augmentations and have carried out joint planning to determine options for these augmentations.

2.7. Reliability Augmentation

It follows from Sections 2.1 – 2.5 that the proposals covered by this application notice constitute a reliability augmentation and that the regulatory test should be applied in accordance with Clause 1(a) of the test.

2.8. Material Internetwork Impact

The Rules require TransGrid to assess whether a proposed new large transmission network asset is reasonably likely to have a material internetwork impact.

TransGrid has determined that none of the options described in Section 3 will impose power transfer constraints or adversely impact on the quality of supply to adjoining transmission networks.

2.9. Consideration of DSM and Local Generation

As the limitations described in Sections 2.5.1 and 2.5.2 currently exist with those in Section 2.5.2 not related to the size of the electrical load it is unlikely that non-network or combined network/non-network options would be suitable to address the limitations described in Section 2.5.

None the less proponents of non-network developments which may relieve the limitations in the transmission network are encouraged to submit proposals in response to this document.

3. Options

The general requirements for options to address the network limitations described in Section 2.5 are summarised as follows:

1. Provide a 132 kV bus section circuit breaker at Orange 132/66 kV substation (or implement an equivalent network development) as soon as practicable;
2. At Orange 132/66 kV substation replace selected 132 kV and 66 kV main equipment, control and protection systems (or implement equivalent network development) and carry out remedial civil works as required; and
3. Loop the Orange – Mt Piper – Wellington 132 kV line 947 into Orange 132/66 kV substation and provide a new 132 kV line switchbay at Orange (or implement an equivalent network development) to enable 944 line to be removed from service for reconstruction (anticipated during 2012).

Note: Works to address requirement 2 above are not an augmentation, however these works will be combined with any option that meets requirements 1 and 3.

TransGrid and Country Energy have developed two network options to address the network limitations detailed in Section 2.5. They are described in the following sections together with descriptions of other network developments that have been considered but not put forward as reasonable options. Due to space constraints at the existing substation both options entail establishment of a second site to the north of the existing substation.

3.1. Option 1: Orange 132 kV Switching Station

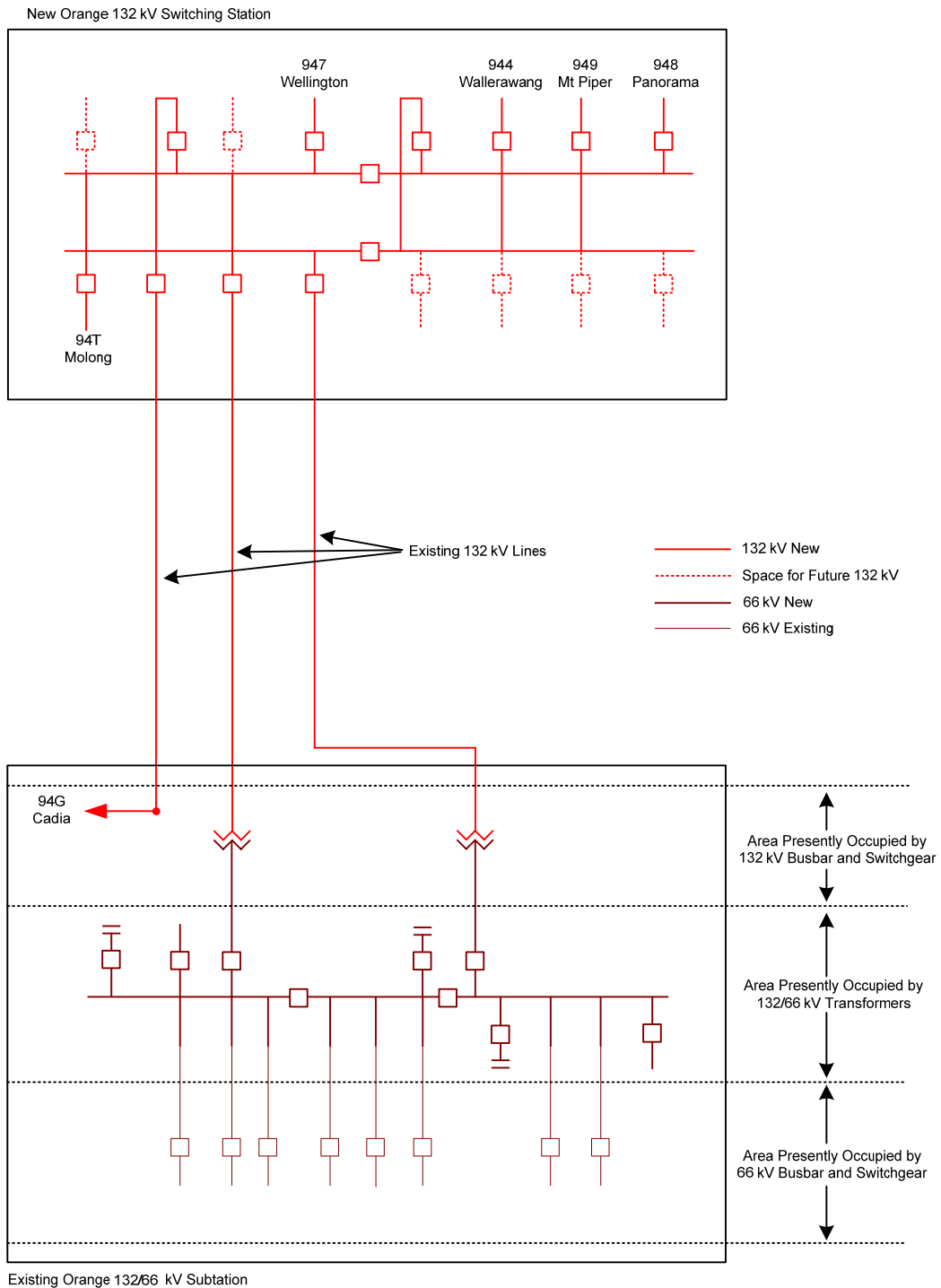

Option 1 is illustrated in Figure 6 above would involve:

- Establishment of a new 132 kV switching station to the north of the existing Orange 132/66 kV substation;
- Looping in of the Orange – Wellington – Mt Piper 132 kV line into the 132 kV switching station;
- Line rearrangements to connect the 132 kV switching station to existing 132 kV lines and to Orange 132/66 kV substation; and
- Telecommunication rearrangements in the Orange area;

These works are estimated to cost \$46 million ($\pm 25\%$) and could be completed by late 2011.

Application Notice - Redevelopment of Orange 132/66 kV Substation

This option would overcome the limitations described in Section 2.5 over at least a ten year planning horizon.

Following completion of Option 1 the following works would be carried out within Orange 132/66 kV substation. These works are also illustrated in Figure 6:

- Removal of redundant 132 kV equipment and relocation of the two 132/66 kV transformers into the area so vacated;
- Construction of a new 66 kV busbar and selected 66 kV switchgear in the area vacated by the relocation of the two 132/66 kV transformers and removal of redundant 132 kV equipment.
- Removal of the redundant 66 kV busbar and other 66 kV equipment;
- Replacement of control and protection systems as required; and
- Remedial civil works as required.

These works are estimated to cost \$10.2 million ($\pm 25\%$) and could be completed by mid 2013.

3.2. Option 2: New Orange 132/66 kV Substation

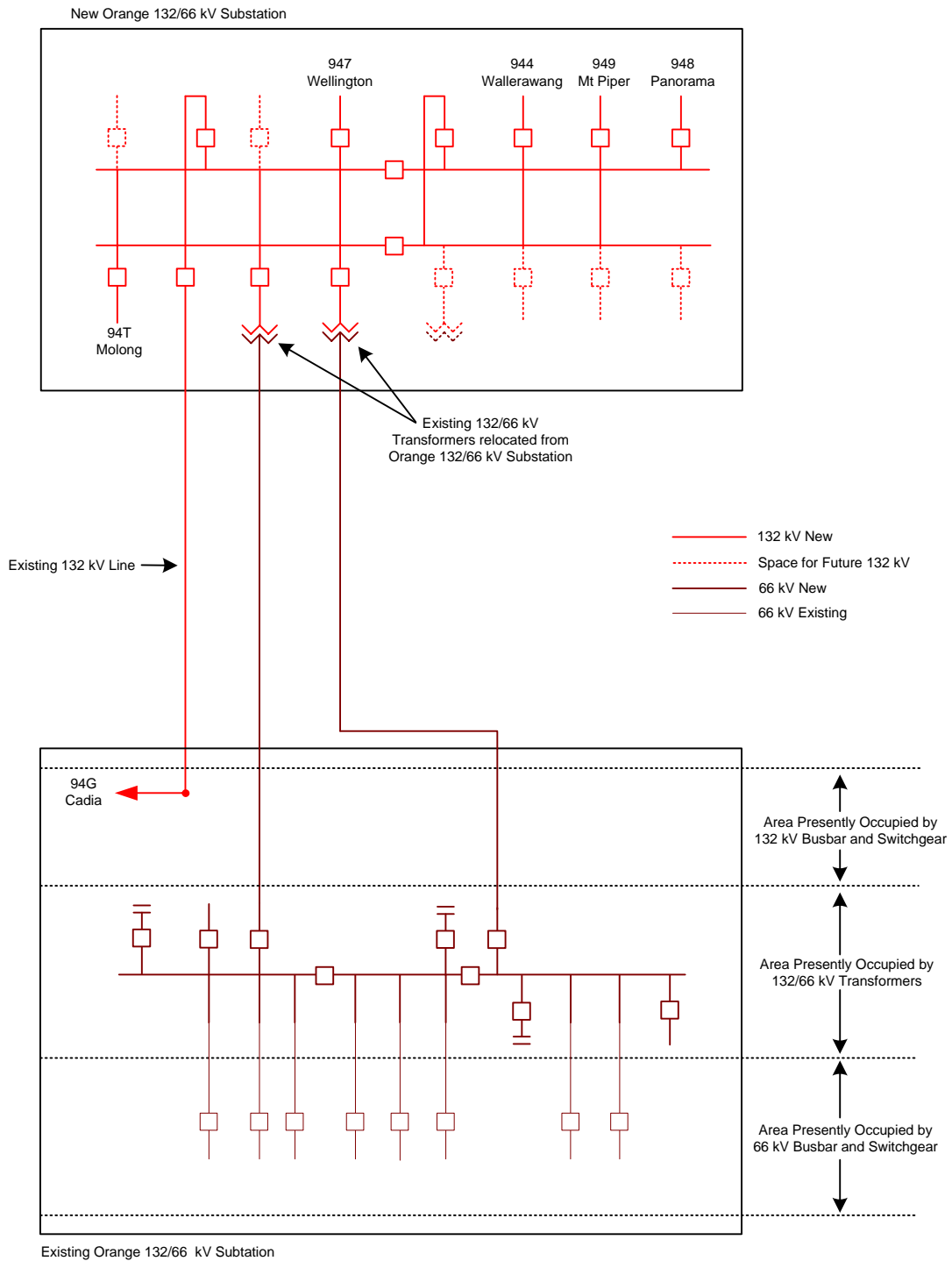

Option 2 is illustrated in Figure 7 above would involve:

- Establishment of a new 132/66 kV substation to the north of the existing Orange 132/66 kV substation using 132/66 kV transformers relocated from Orange 132/66 kV substation;
- Looping in of the Orange – Wellington – Mt Piper 132 kV line into the new 132/66 kV substation;
- Line rearrangements to connect the new 132/66 kV substation to existing 132 kV lines;
- Reconstruction of two 132 kV circuits between the 132/66 kV substation and the existing Orange 132/66 kV substation as 66 kV with higher capacity conductor; and

Application Notice - Redevelopment of Orange 132/66 kV Substation

- Telecommunication rearrangements in the Orange area;

These works are estimated to cost \$58 million ($\pm 25\%$) and could be completed by late 2011.

This option would overcome the limitations described in Section 2.5 over at least a ten year planning horizon.

Following completion of Option 2 the following works would be carried out within Orange 132/66 kV substation. These works are also illustrated in Figure 7:

- Removal of redundant 132 kV equipment;
- Construction of a new 66 kV busbar and selected 66 kV switchgear in the area vacated by the relocation of 132/66 kV transformers to the new 132/66 kV substation and removal of redundant 132 kV equipment.
- Removal of the redundant 66 kV busbar and other 66 kV equipment;
- Replacement of control and protection systems as required; and
- Remedial civil works as required.

These works are estimated to cost \$3.1 million ($\pm 25\%$) and could be completed by mid 2013.

3.3. Notes on Options 1 and 2

1. Circuit breaker quantities and arrangements shown in Figures 6 and 7 are indicative.
2. The staging of works for Option 1 and Option 2 and the 66 kV works within Orange 132/66 kV substation is quite complex and is not shown.
3. It may be necessary to use short sections of cable near both sites to complete line connections. The above cost estimates include an allowance for this possibility.
4. Works within the existing Orange 132/66 kV substation are required for asset condition reasons and do not form part of Options 1 and 2. They have been included for completeness.

3.4. Consideration of Other Network Developments

3.4.1. Other Sites in the Orange Area

Options 1 and 2 have been costed based on a preferred site in the north Orange area. Other sites have been considered with the choice of the preferred site being based on site characteristics, cost, complexity of line rearrangements, community impacts and environmental impacts.

3.4.2. Expansion and Refurbishment of Orange 132/66 kV Substation

As described in Section 2.5.1 Orange 132/66 kV substation is in the central part of Orange and is bounded on all sides by various urban developments. There is no free space at the site to accommodate the new 132 kV bus section circuit breaker and 132 kV line switchbay described in Sections 2.5.1 and 2.5.2. Expansion of the substation on adjacent land is not feasible. The lack of free space also precludes a staged redevelopment of the substation on the existing site.

4. Preliminary Application of the Regulatory Test

A preliminary application of the regulatory test, considering Options 1 and 2, has been carried out. A summary of the results is provided in the following sections.

4.1. Form of the Regulatory Test

As discussed in Section 2 the options covered by this application notice are a reliability augmentation and the regulatory test is to be applied in accordance with clause 1(a) of the test:

- (a) in the event the option is necessitated principally by inability to meet the service standards linked to the technical requirements of schedule 5.1 of the Rules or in applicable regulatory instruments - the option minimises the costs of meeting those requirements, compared with alternative option/s in a majority of reasonable scenarios;

TransGrid's interpretation of the regulatory test for reliability augmentations is as follows.

The following costs should be included:

- Capital costs of options;
- O&M costs of options; and
- Costs of complying with laws, regulations and applicable administrative requirements in relation to the option;

The following avoided costs should not be included:

- Reductions in electrical losses;
- Reductions in unserved energy;
- Deferrals or avoidance of generation or transmission investment elsewhere in the NEM (ie not associated with the option); and
- Avoided fuel costs elsewhere in the NEM.

Market development scenarios are only relevant to the extent that they affect the timing of the onset of network limitations and/or the ability of options to meet those limitations.

4.2. Preliminary Regulatory Test Application – Summary

4.2.1. Costs

For the preliminary regulatory test application only the capital and operating & maintenance costs of Options 1 and 2 have been explicitly included.

There are no known existing or anticipated government tax or subsidy schemes that would apply differently to the operation of Options 1 and 2.

There are no known emerging network limitations in the area (other than those described in Section 2.5) for which the solution would be differently affected by either of these options.

4.2.2. Scenarios

Only a single market development scenario has been considered which corresponds to a medium economic growth outcome and which does not explicitly model future generation or demand management developments. This is due to:

- The need for network augmentation being within the lead time of all known reasonable options.
- There being no known committed or advanced generation or demand management developments that are likely to affect the timing of the onset of the network limitations or the ability of any reasonable option to meet them.

Application Notice - Redevelopment of Orange 132/66 kV Substation

4.2.3. Results

The present value of the costs of each option has been calculated for a base case of financial and technical assumptions and the options ranked accordingly. Sensitivity tests of these calculations due to reasonable variations to the major assumptions have been carried out.

The base case assumptions and the range over which sensitivity tests were conducted are shown in Table 3. The results of the analysis are shown in Table and Table. Details of the costing model for the base case assumptions are shown in Appendix A.

Table 3 Base Case Values and Range of Values Used in Sensitivity Checks

Parameter	Base Case Value	Sensitivity Checks at
Real Discount Rate	9%	6% and 12%
Annual O&M Cost	2% of Capital Cost	1% and 3% of Capital Cost
Asset Lifetimes		
Substations	30 years	20 and 40 years
Transmission Lines	45 years	30 and 60 years
Capital Costs	Nominal Value	±25% variation

Table 4 Comparison of Options – Base Case

Option	Capital Costs (\$M)	PV of Costs (\$M)	Rank
Option 1	45.7	23.3	1
Option 2	57.9	29.5	2

Table 5 Comparison of Options - Results of Sensitivity Studies

Sensitivity Case	Option 1 PV of Costs (\$M)	Rank	Option 2 PV of Costs (\$M)	Rank
Base Case	23.3	1	29.5	2
12% Discount Rate	22.8	1	28.8	2
6% Discount Rate	23.0	1	29.1	2
25% Increase in Capital Costs	29.1	1	36.8	2
25% Decrease in Capital Costs	17.5	1	22.1	2
Decrease in Asset Lives	25.2	1	31.9	2
Increase in Asset Lives	22.3	1	28.2	2
Decreased O&M Cost	21.6	1	27.4	2
Increased O&M Cost	24.9	1	31.5	2

In each case Option 1 has lower present value of costs and is therefore the highest ranked option.

5. Preliminary Conclusions and Preferred Actions

At this stage and subject to comments received during the consultation process TransGrid and Country Energy conclude that Option 1 would satisfy the regulatory test. The preferred actions would be for TransGrid to proceed with construction of Option 1 plus the associated 66 kV refurbishment works within Orange 132/66 kV substation as described in Section 3.1.

6. Contact Details for Submissions and Enquiries

In accordance with the Rules TransGrid and Country Energy invite written submissions from interested parties on this application notice.

Submissions are due by 21/04/2009.

Submissions or other enquiries should be directed by email to:

regulatory.consultation@transgrid.com.au

Application Notice - Redevelopment of Orange 132/66 kV Substation

Appendix A - Present Value Cost Analysis of Base Case

**Redevelopment of Orange 132/66 kV Substation: Preliminary Application of the Regulatory Test
Option 1: North Orange Switching Station**

	2009	2010	2011	2012	2013	2014	2015	2016	2017	2018	2019	Residual
132 kV site development				23.1								-16.9
Line rearrangements				14.3								-11.7
Telecommunications				8.4								-6.1
O & M Costs					0.9	0.9	0.9	0.9	0.9	0.9	0.9	
Total Costs				45.7	0.9	0.9	0.9	0.9	0.9	0.9	0.9	-34.8
PV of Costs	23.3	million										
Total Capital Cost	45.7	million										

**Redevelopment of Orange 132/66 kV Substation: Preliminary Application of the Regulatory Test
Option 2: North Orange Substation**

	2009	2010	2011	2012	2013	2014	2015	2016	2017	2018	2019	Residual
132 kV site development				31.0								-22.7
Line rearrangements				18.6								-15.3
Telecommunications				8.4								-6.1
O & M Costs					1.2	1.2	1.2	1.2	1.2	1.2	1.2	
Total Costs				57.9	1.2	1.2	1.2	1.2	1.2	1.2	1.2	-44.1
PV of Costs	29.5	million										
Total Capital Cost	57.9	million										