

**Transgrid**

180 Thomas Street  
Sydney NSW 2000  
regulatory.consultation@transgrid.com.au

Anthony Yarrow

26<sup>th</sup> March 2025

## ib vogt submission to RIT-T Wagga North Capacity Increase PSCR

Dear Transgrid Regulation Team,

This submission is in support of Transgrid and the PSCR for Increasing Capacity for Generation in Wagga North Area, aimed at alleviation of curtailment of solar generation within the Wagga North Area and thus providing the maximum utilisation of the existing network.

Ib vogt currently has Wagga North BESS (AEMO KCI ID N00184) under development and proposing to connect to the 132kV Wagga North Substation with an expectation that both the size of 120MW and duration of 4 hours is expected to provide materially significant alleviation of existing system normal constraint equations associated with thermal transfer limits of transmission lines 9R5 and 9R6 as well as a number of other system normal and contingency constraint equations thus providing a sophisticated non network solution for the RIT-T under consideration.

Ib vogt's BESS has both the technical and operational characteristics to contribute to meeting the identified need, due to the size, location and ability to operate up to 4-hour charge during times when renewable energy is constrained and discharged at other times.

The BESS is expected to be commercially available from 1<sup>st</sup> July 2027.

Ib vogt would like to raise a number of inputs as part of the PSCR process with the view of supporting Transgrid in achieving optimal usage of their existing network.

1. **Historical curtailment; existing NEMDE constraint equations governing curtailment of Wagga North Generation:**

- We recognise the assessment of generator curtailment in regards to both MW and GWh caused by transfer limits associated with the system normal management of contingency of combinations of 9R6,9R5 and 991. As per the PSCR the projected curtailment was based upon an internal model to predict curtailment in 2025.
- We would like to provide some further detailed assessment of our view based upon the most recent 12 month period of the operation and resulting curtailment of generation and to achieve this we have assessed actually available capacity and compared it with dispatch instruction from NEMDE and then compared with both constraint equations directly associated with the thermal limit of lines 9R5 and 9R6 while eliminating curtailment potentially associated with transfer limits further upstream in Essential Energy's network
- Thermal constraint equations governing transfer limit of lines 9R5 and 9R6 causing curtailment of generation
  1. N>NIL\_9R6\_991 – System normal; avoid overload of Wagga North to Wagga (9R6) 132kV line on trip of Wagga North to Murrumburrah (991) 132kV line
  2. N>NIL\_9R6\_9R5 – System normal; avoid O/L Wagga North to Wagga132 (9R6) on trip of Wagga North to Wagga330 (9R5) line
  3. N>NIL\_9R5\_9R6 - Out= Nil; avoid O/L Wagga North to Wagga330 (9R5) on trip of Wagga North to Wagga 132 (9R6) line
- Constraint equations causing curtailment of generation in Wagga North region not associated with thermal limit of 9R5 and 9R6
  1. N>NIL\_901- System normal; avoid overload West Wyalong to Temora 132kV (901) line on trip of Nil
  2. N>NIL\_9J5/2 – System normal; avoid overload Temora to Junee T 132kV (9J5/2) line on trip of Nil
  3. N>NIL\_99U – System normal; avoid overload Sebastopol to Wagga North (99U) 132kV line on trip of Nil
  4. N>>NIL\_990\_051 – System normal; avoid overload Wagga to Yass (990) on trip of Wagga to Lower Tumut (051) line
  5. N>>NIL\_991\_051 – System normal; avoid overload Wagga North 132 to Murrumburrah 132 (991) on trip of Wagga to Lower Tumut (051) line

- First, we evaluated the total technical curtailment i.e. curtailment resulting from power system limits rather than due to negative whole spot price with the following result

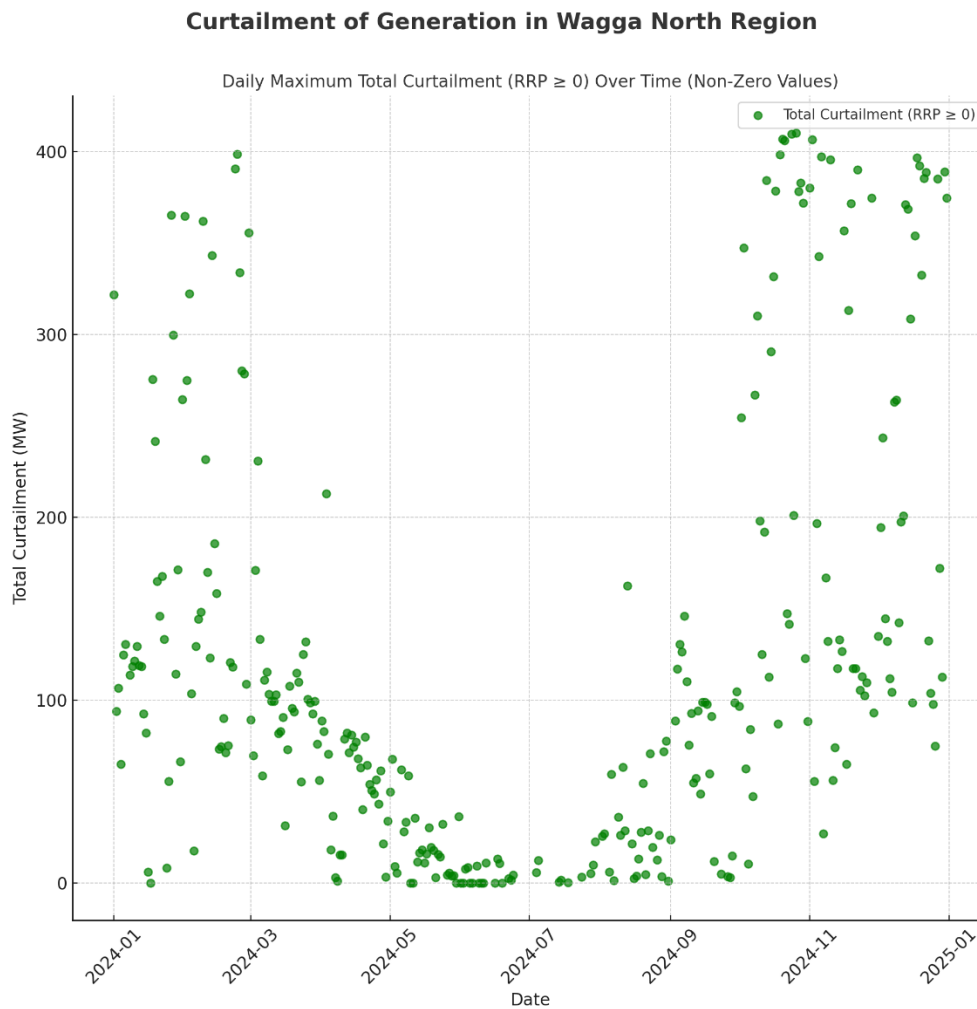

- It is valuable to understand that while components of this curtailment of generators in the Wagga North region are associated with the thermal limits of lines 9R5 and 9R6, there are a number of other constraint equations in the area which are both system normal and contingency that have resulted in curtailment of this generation. While not specific to this RIT-T, our proposed project is expected to contribute to alleviation of both the limits of 9R5/9R6 as well as this wider set of transfer limits.
- We then undertook a further analysis to confirm when the relevant constraint sets for system normal 9R5 and 9R6 which yielded the following mapping of maximum curtailment in the calendar year of 2024. Notably there is already substantial magnitudes of curtailment occurring in the Wagga North region historically.

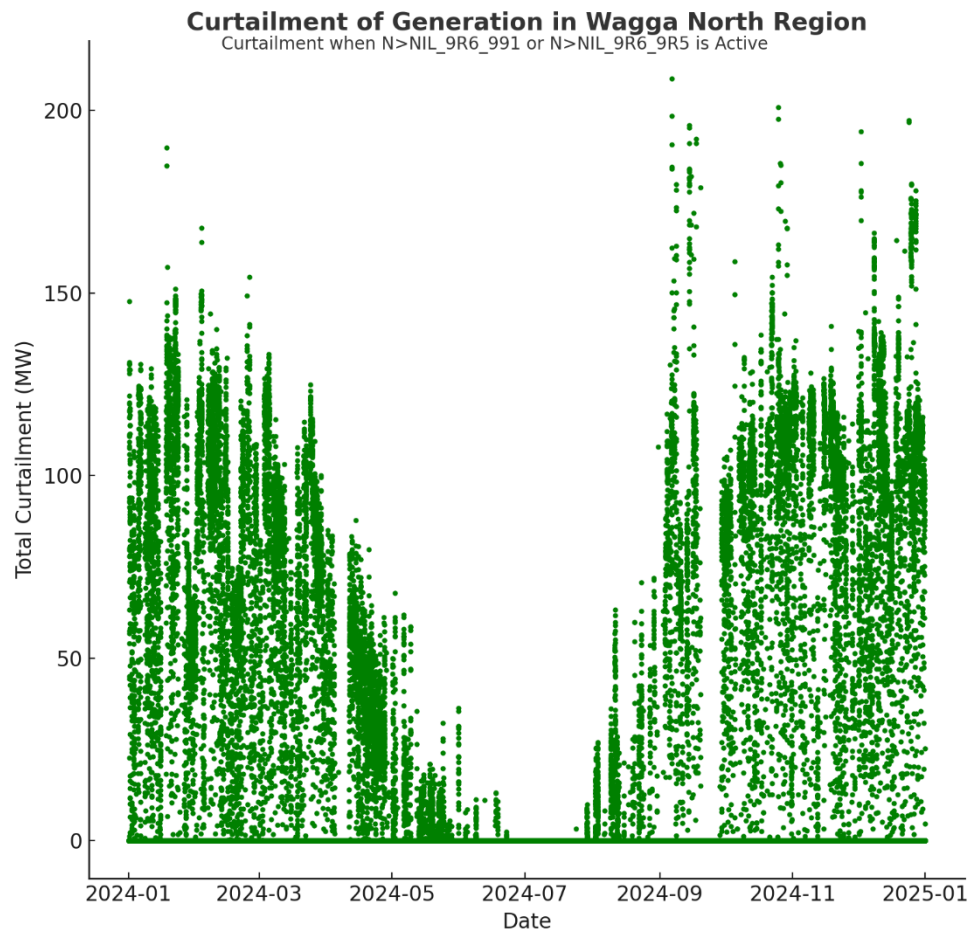

- The analysis indicates that with current system configuration and load and generation profiles that there is already a need for additional transfer capacity in excess of 100MW without considering any further generation, storage or network augmentations that might further impact curtailment in this region.
- The network solutions proposed for this RIT-T including option 1-4 might be best suited as combined with a longer term non network solution of a BESS project for the interim period until these network solutions can be deployed but critically also beyond this initial period for more severe curtailment events and changes in load flow that might still result in a magnitude of curtailment in the Wagga North Region beyond what the proposed RIT-T solutions can achieve.

**2. Power flow analysis of future network augmentations:**

- We undertook a simple load flow analysis considering summer minimum demand scenario as the most appropriate to take into account minimum transmission line limits combined with typically maximum rooftop and utility scale PV generation. This coincides with the most significant curtailment of generation in the Wagga North region for this exact reason.
- We only looked to a simplistic comparison of different probable network augmentations and storage (load) projects that we expected to have the highest

proportionate impact on curtailment. We only looked at system normal and did not take into account existing constraint equations such as  $N > \text{NIL\_9R6\_9R5}$  or  $N > \text{NIL\_9R6\_991}$  that are used to manage risk of contingency events during system normal. We only looked to assess a proportionate increase in power flow for different network changes:

1. Base case – The network as it currently operates

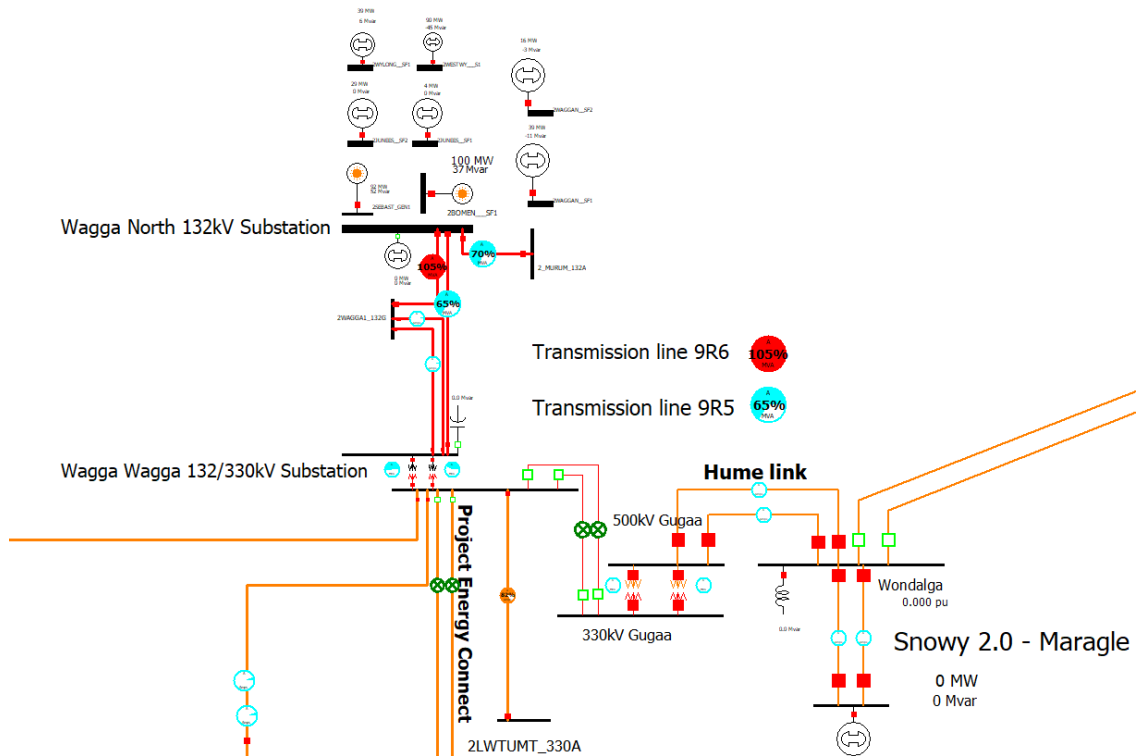

This scenario included ramping generation up to its maximum output resulting in overload of line 9R6. In reality this does not occur due to constraint  $N > \text{NIL\_9R6\_9R5}$  or  $N > \text{NIL\_9R6\_991}$  which each manage the possibility of outage of 9R5 and 991 network elements resulting in overload of remaining network elements.

2. Commissioning of large scale BESS at Wagga 330kV substation

There is currently 600MW of BESS submitted under development applications at the 330kV Wagga Wagga substation with a further 300MW proposed. Adding this BESS to the load flow in charging configuration results in substantial additional power flows through 9R6 and 9R5

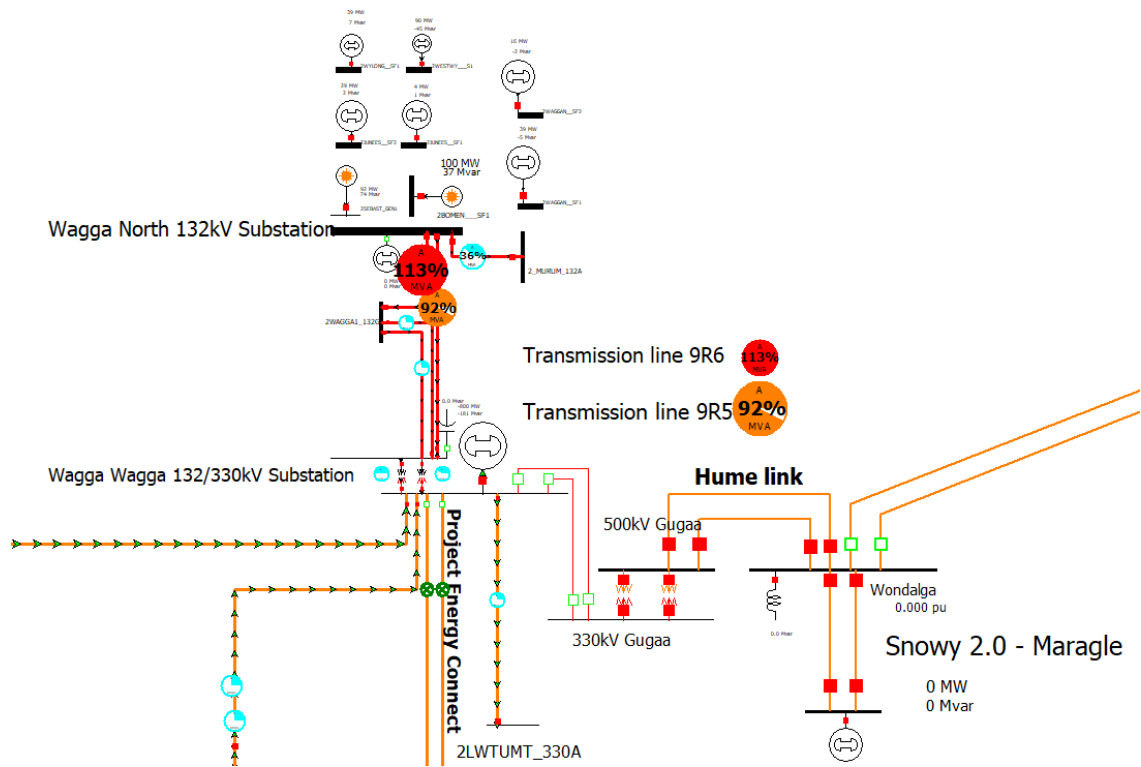

### 3. Energisation of Humelink and Snowy 2.0

Energisation of Humelink and operation of Snowy 2.0 in pumping mode is expected to coincide with peak solar generation output similar to how BESS are expected to operate. We have factored the energisation of Project Energy Connect but not the substantial amount of wind, solar and BESS and expect that flows during the day may be limited due to this combination of generation and storage.

The result we see is again similar and as expected to the operation of BESS at the 330kV Wagga Wagga Substation that does further increase flows along 9R6 and 9R5.

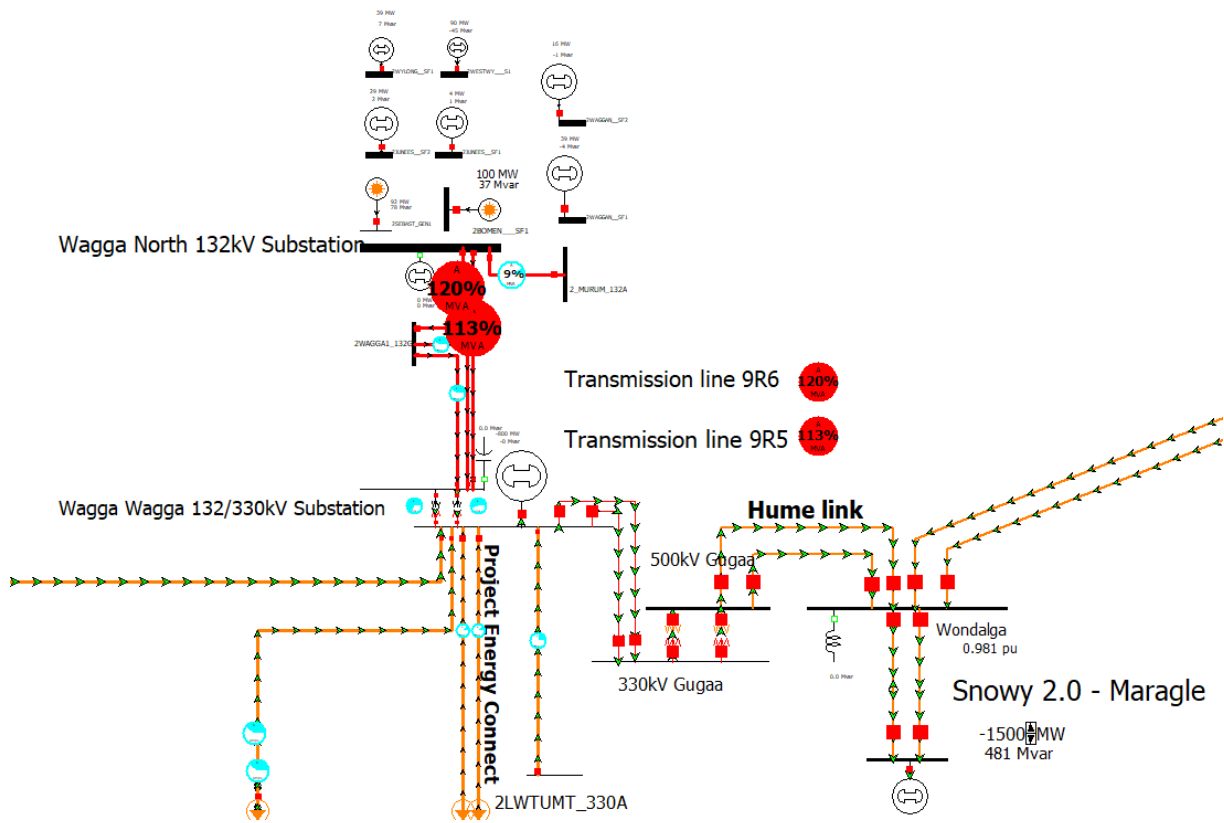

### 3. Recommendations:

- Assessment of timeline and major network change scenarios such as energisation of Snowy 2.0 and deployment of BESS at Wagga Wagga 330kV which may result in persistent curtailment even with some of the augmentation options deployed,
- Look at a longer term non network solution and possibly larger quantum of network transfer capacity required such as through a BESS that would help provide a hedge against the system limits of some of the network augmentations outlined in the PSCR.

ib vogt Australia would like to further offer its support and engagement throughout the RIT-T process for increasing generation in the Wagga North region and are hopeful of a solution that addresses the needs to the system now and in the future.

Warm Regards,

Joel Haddow  
Development Manager